

# ROBINSON R22 INTERIOR INSTALLATION INSTRUCTIONS

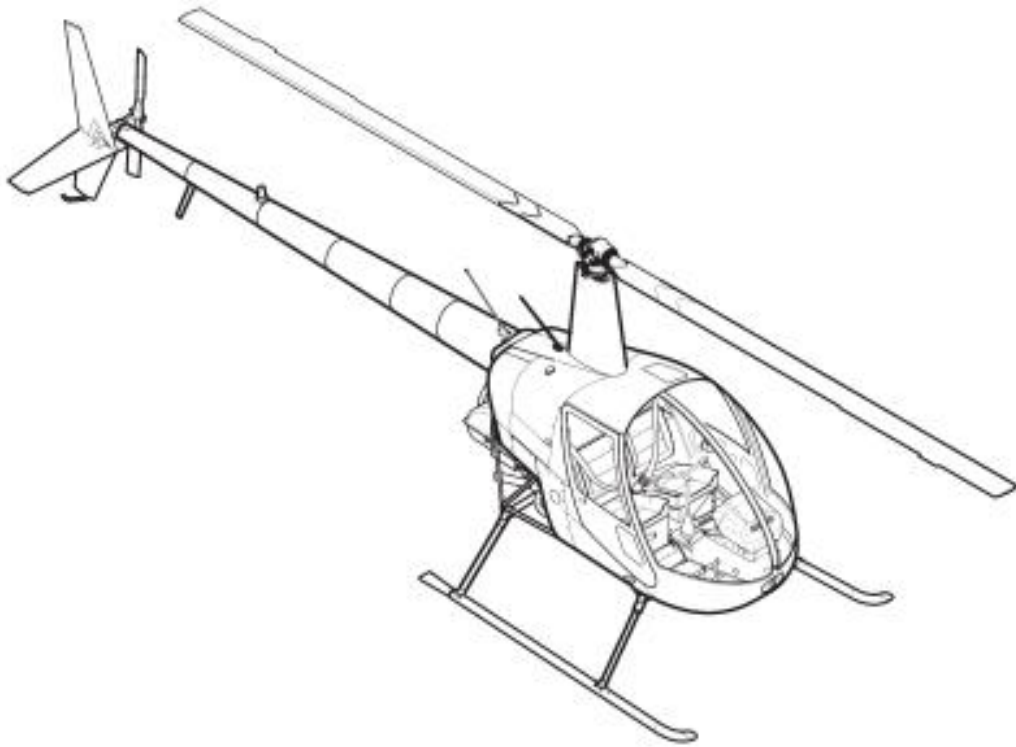

- HEADLINING
  - SEAT COVERS
  - CARPETS

# Contents

<b>Seating</b>	<b>3</b>
This kit contains.....	4
Instructions for fitting.....	5
Cleaning Instructions.....	6
Recommended Products.....	7
Further Information .....	7
<b>Headlining</b>	<b>8</b>
This kit contains.....	9
Instructions for fitting.....	10
Cleaning Instructions.....	11
Recommended Products.....	12
Further Information .....	12
<b>Carpets</b>	<b>13</b>
This kit contains.....	14
Instructions for fitting.....	15
Cleaning Instructions.....	16
Recommended Products.....	17
Further Information .....	17

# This Pack Contains:

## SEAT ASSY - GENERATION #1

Items	P/n:	Qty
SEAT ASSY, BACKREST	A003-13-GEN1	2
SEAT ASSY, BOTTOM	A928-1-GEN1	2

## SEAT ASSY - GENERATION #2

Items	P/n:	Qty
SEAT ASSY, BACKREST	A003-13-GEN2	2
SEAT ASSY, BOTTOM	A928-1-GEN2	2

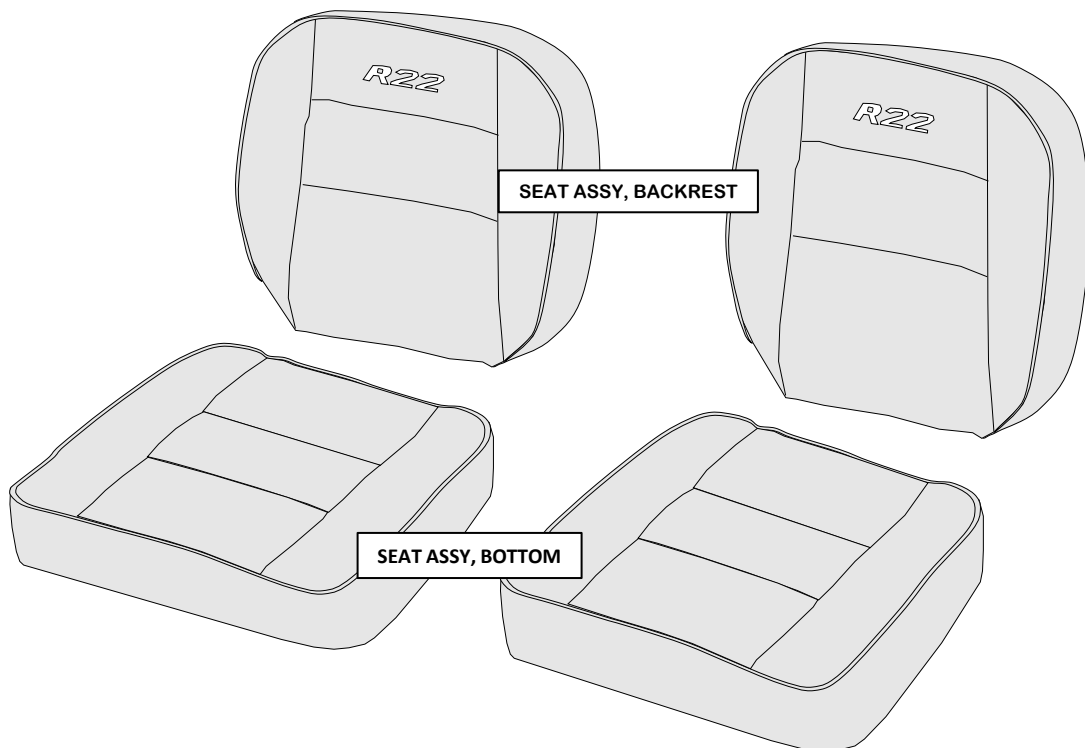

# Instructions for fitting

1. Remove the seating from the helicopter in accordance with the R22 Maintenance Manual. De-riquet the aluminium retainer strips & backing plates from all seat assy's. Remove the old seat coverings & foam cushions from off the backing panels & seat pans.

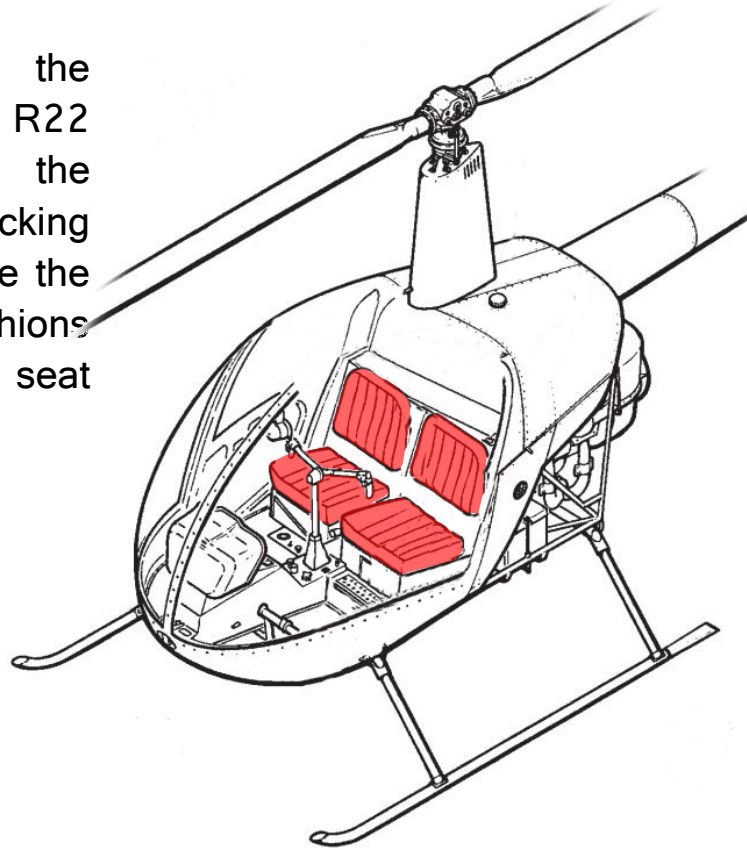
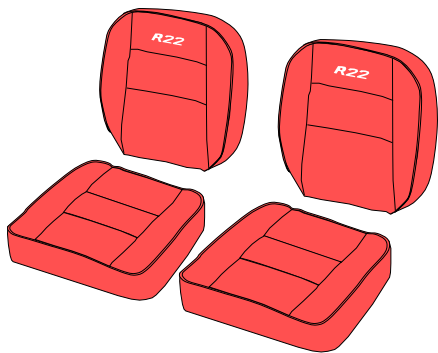

2. Take the new cover/cushion assy's & turn the leather side borders back from foam cushion, turning the leather covers inside out.

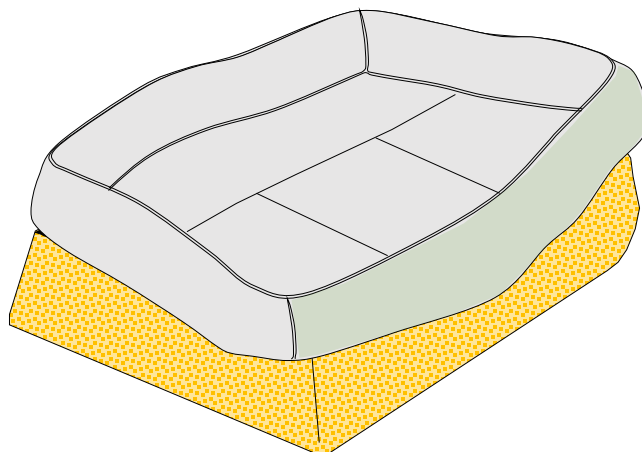

3. Using contact adhesive, glue the seat backrest foam cushions to the aluminium backing panels & the seat bottom foam cushions to the composite seat pans as previously glued. Take care to centre up & align the foam cushions on to these panels.

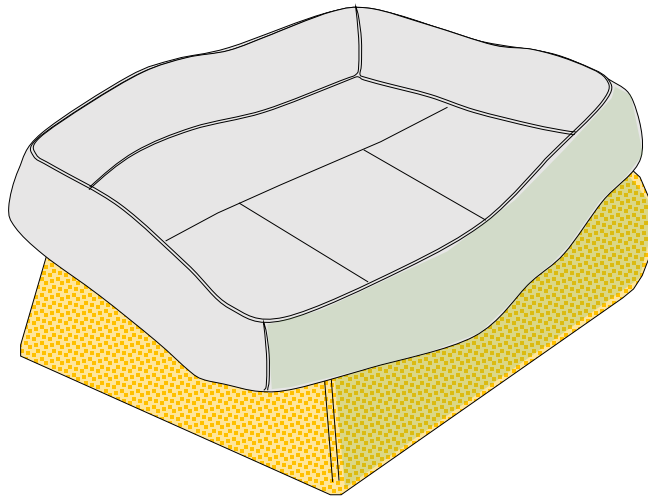

4. Glue the side border panels of the dress covers & the outside edges of the aluminium seat backing panels & composite seat pans.

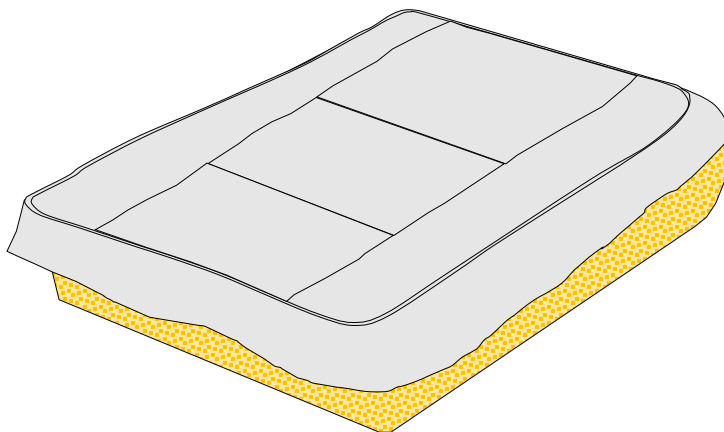

5. Roll the leather side borders down over the foam cushion and tension the sides of the covers slightly before adhering in place, starting in the corners.

	<b>Robinson R22 Interior Installation Instructions</b>
	<b>Seating Gen I &amp; GEN II</b>

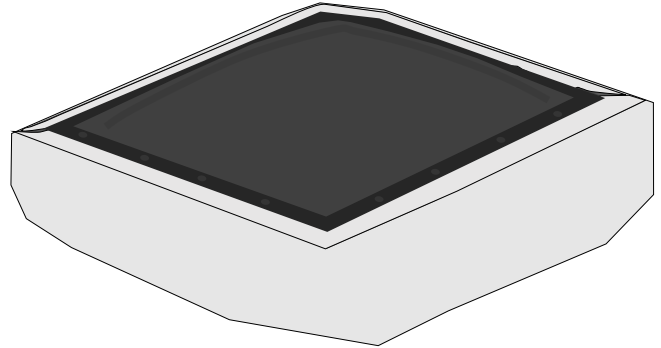
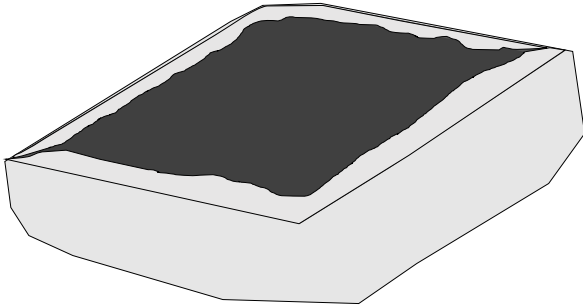

6. Seat Bottoms: Open the existing rivet holes with a 1/8 drill & re-attach the four aluminium retainer strips around the edges using rivets supplied. Using a box cutter/knife, remove any excess leather showing on the inside edges of the retainer strips, being careful not to cut into the composite pan.

*“Optional, for optimum effect the installer may mask off all leather surfaces on the seat bottom pans & wipe down painted surfaces with solvent cleaner & prepare for painting. Spray paint seat bottom with black paint & de-mask”.*

7. Seat Backrests: Open the existing rivet holes with a 1/8 drill & re-attach the aluminium backing panels using the rivets supplied.

8. Install the seating into the airframe in accordance with the R22 maintenance manual.

### Cleaning Instructions

Clean any excess glue away with a mild solvent taking care that the solvent does not damage any leather. For general cleaning, wipe surfaces with damp cloth using water and a mild detergent. For all queries, please call Generation Global.

### Recommended Products

- Paint: Refer to Robinson Service Manuals
- Cleaning: Dupont Prep-Sol. – Composites & metals.

Wipe leather with damp cloth using mild soapy water

- Glue: Robinson B270-8  
Ados F2  
Bostik Super-tac  
Daley's A1000 (Australia)  
3M, 1300L

**Generation Global takes no responsibility for installation outside the instructions above and for use of solvents and chemicals used other than those recommended above, if in doubt refer to the Robinson Maintenance Manuals for the correct materials.**

# This Pack Contains:

Items	P/n:	Qty
REAR BULKHEAD	A003-2-GEN	1
QUARTER PANEL, LH	A003-10-GEN	1
QUARTER PANEL, RH	A003-15-GEN	1
CEILING, LH	A914-1-GEN	1
CEILING, RH	A003-3-GEN	1

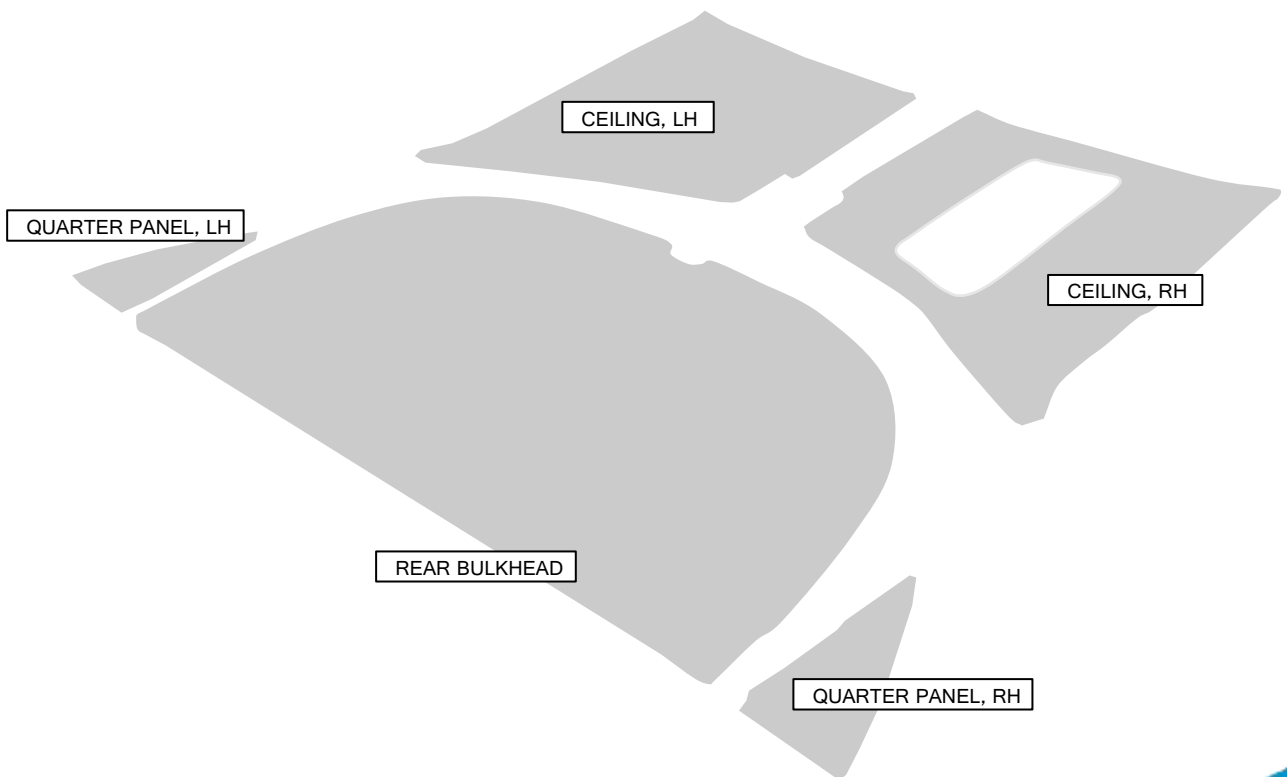



# Instructions for fitting

1. Remove old headlining panels, seatbelt hardware and headphone output unit in accordance with the R22 Maintenance Manual.

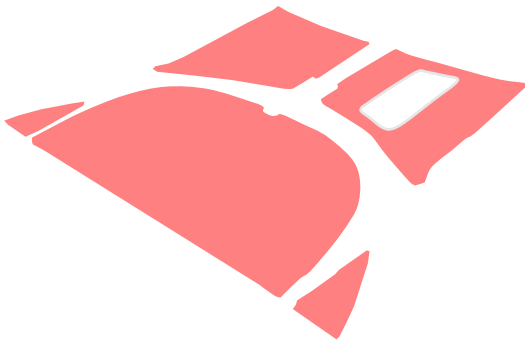
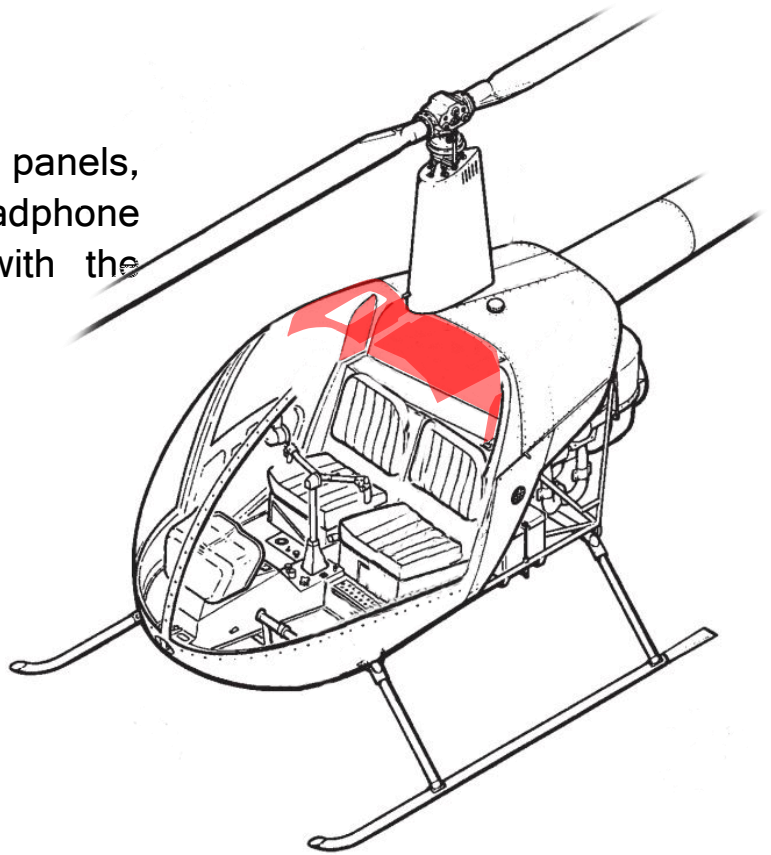

2. Remove all the old foam insulation and adhesive residue using a plastic scraper or putty knife. Prepare the surfaces by wiping clean, using a clean cloth wet with acetone.

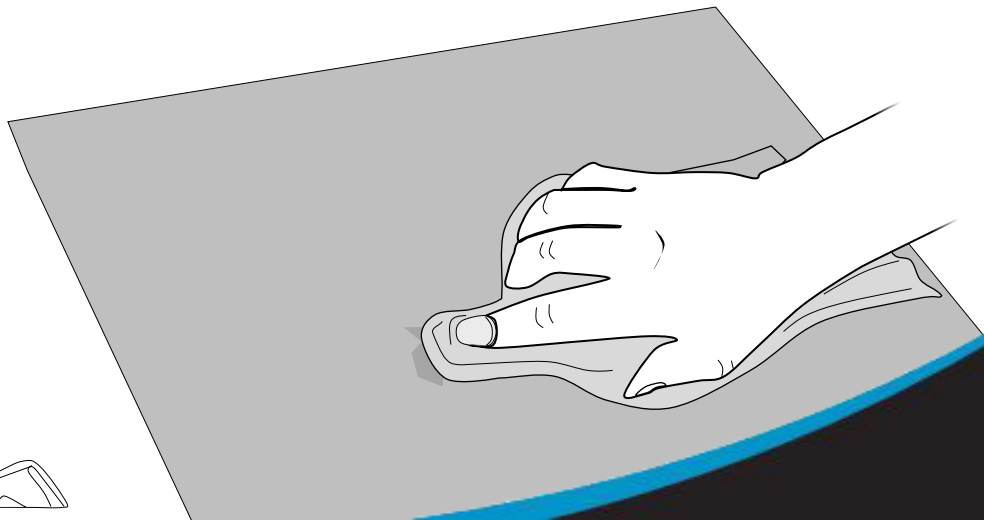

3. Take care to mask out any areas that may be affected by solvents and glues, such as Perspex windows and flight instruments.

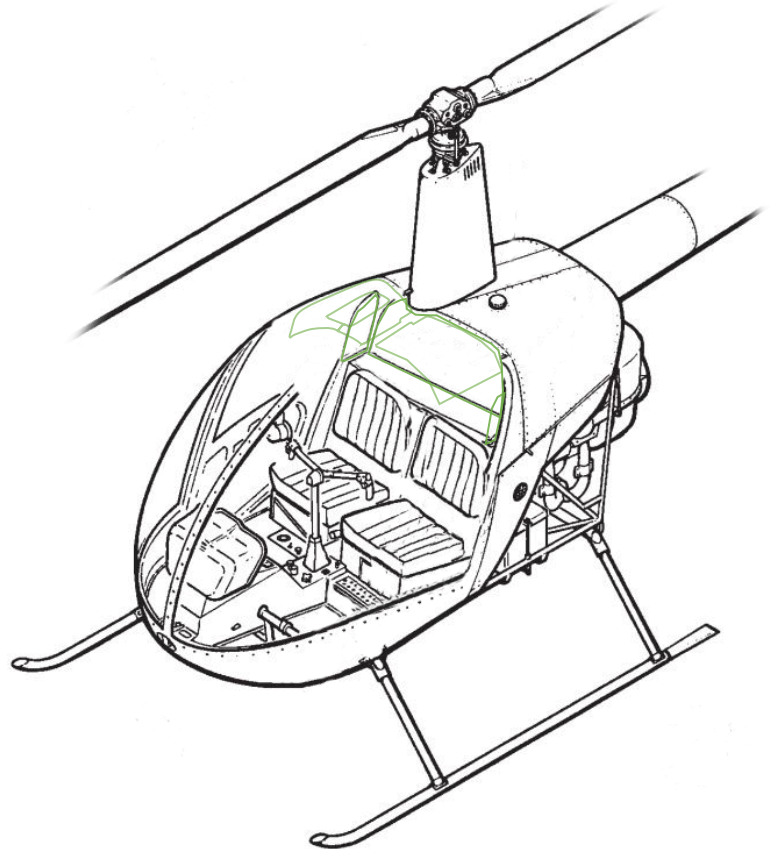
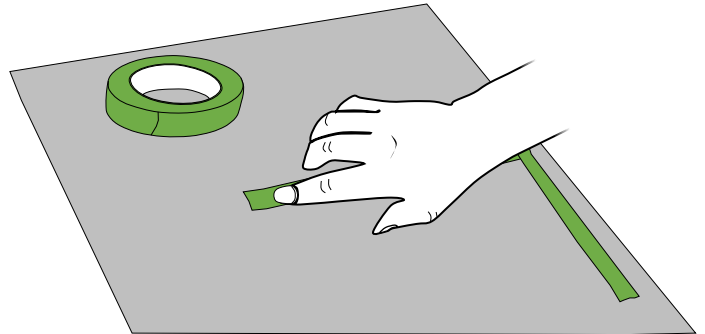

4. Verify proper fit of the new panels and trim as required.

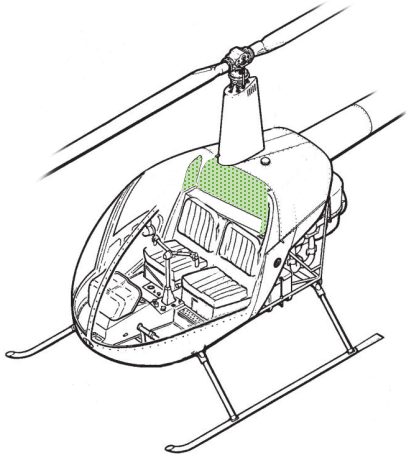

4. Apply contact adhesive to the rear of the 5 panels leaving them in a clean dry area. Apply contact adhesive to the two ceiling panel areas. Start attaching carefully, beginning at the front centre corners, the smooth back to the rear, taking care to align the roof window, so no edges are seen. Trim & tuck the loose excess panel behind metal edges.

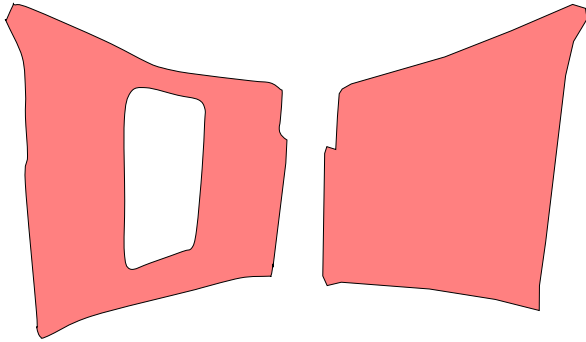

5. Apply contact adhesive to the 2x Pillar sections and place the panels in position, tucking in all edges & smooth out.

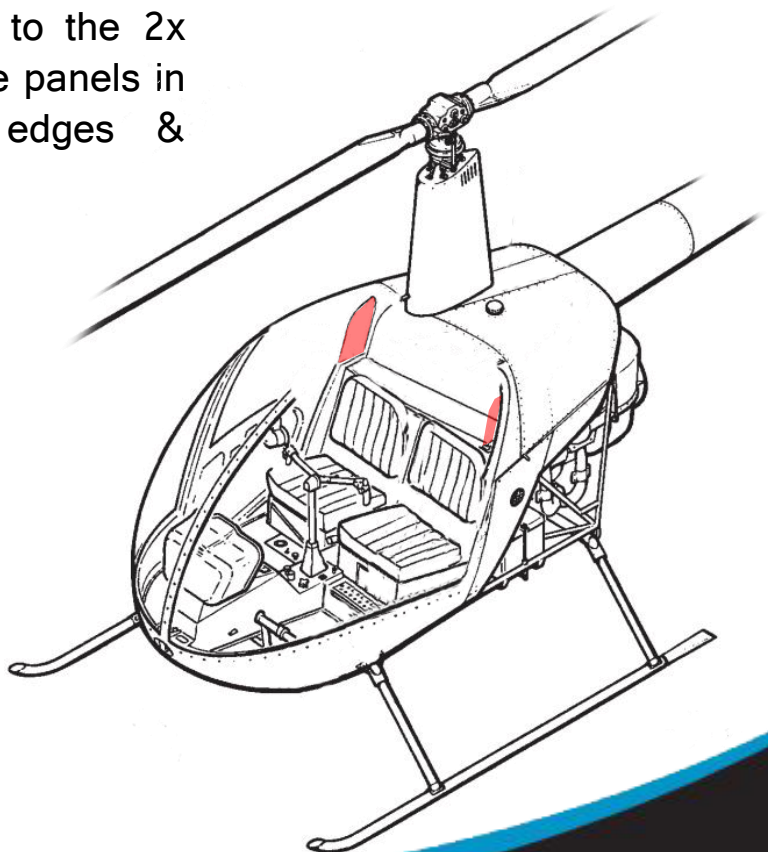
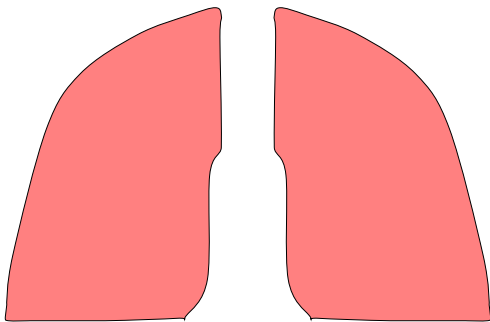

6. Apply contact adhesive to the rear firewall panel. Place the panel in position and smooth out from the centre, evenly, in all directions. Butt all edges up with the previously installed panels and framework.

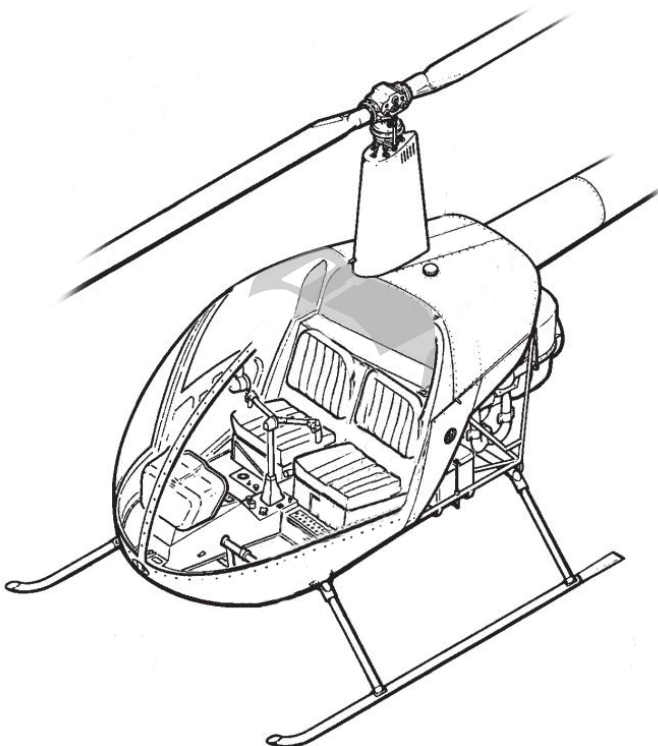
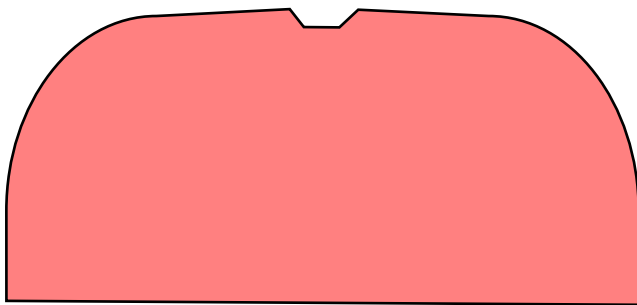
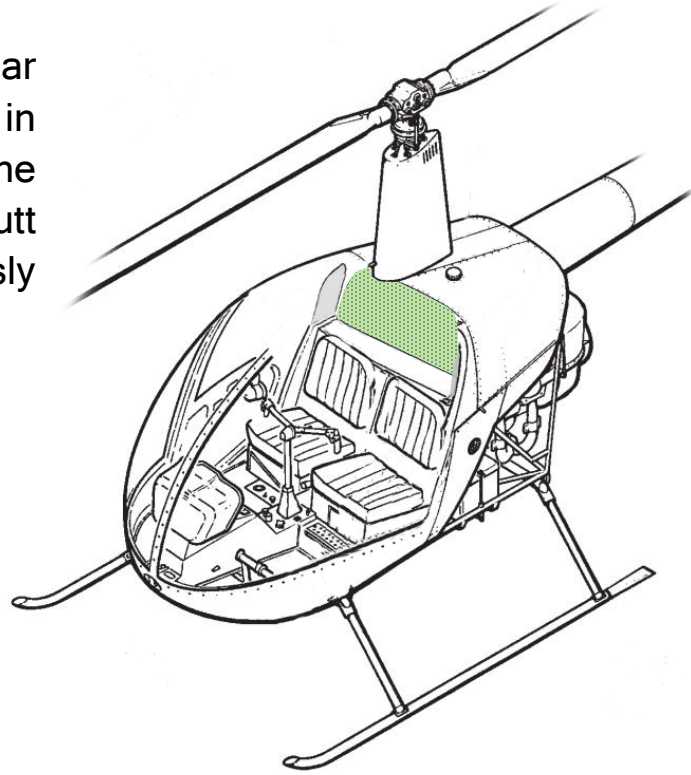

7. Install the seatbelt hardware and headphone output unit in accordance with the R22 Maintenance Manual. Use a skewer or similar sharp object to mark any holes that you need to cut.

### Cleaning Instructions

Clean any excess glue away with a mild solvent taking care that the solvent does not damage any Perspex windows or plastics, remove any masking that you may have used and clean any fabric area with water and a mild detergent. Products recommended for fabric are fine as well, only take care to read the products application details. For any queries, please call Generation Global.

### Recommended Products

- **Cleaning:** Dupont Prep-Sol. – Composites & metals  
Acetone – Composites & metals  
Water & mild soapy detergent – Fabric.
- **Glue:** Robinson B270-8  
Ados F2 (aerosol can)  
Ados F38  
Bostik Super-tac (aerosol can)  
Daley's A1000 (Australia)  
3M 1300L

**Generation Global takes no responsibility for installation outside the instructions above and for use of solvents and chemicals used other than those recommended above, if in doubt refer to the Robinson Maintenance Manuals for the correct materials.**

# This Pack Contains:

Items	P/n:	Qty
FOOTWELL, RH	A469-34-GEN (Alt: A469-2-GEN)	1
FOOTWELL, LH	A469-33-GEN (Alt: A469-1-GEN)	1
SEAT BULKHEAD, RH	A469-27-GEN (Alt: A469-4-GEN)	1
SEAT BULKHEAD, LH	A469-18-GEN (Alt: A469-3-GEN)	1
SIDE, FWD, RH	A469-12-GEN	1
SIDE, FWD, LH	A469-11-GEN	1
SIDE, AFT, RH	A469-14-GEN	1
SIDE, AFT, LH	A469-13-GEN	1

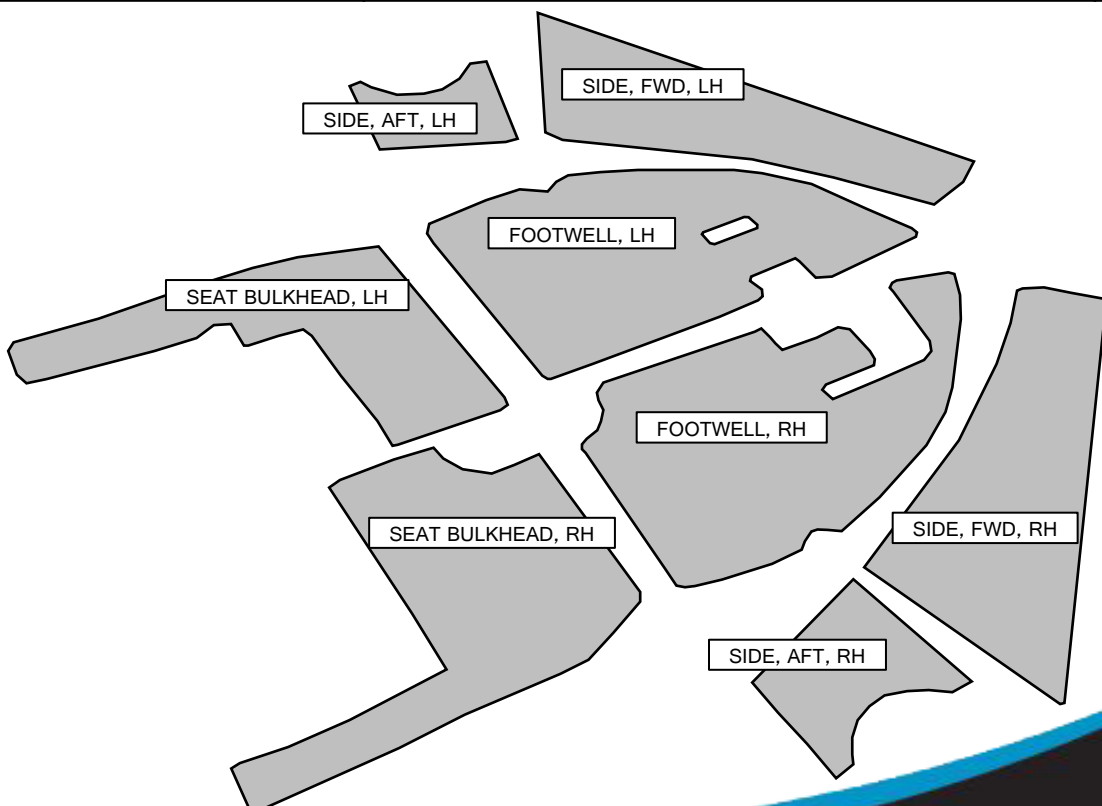

# Instructions for fitting

1. Remove old carpets in accordance with the R22 Maintenance Manual.

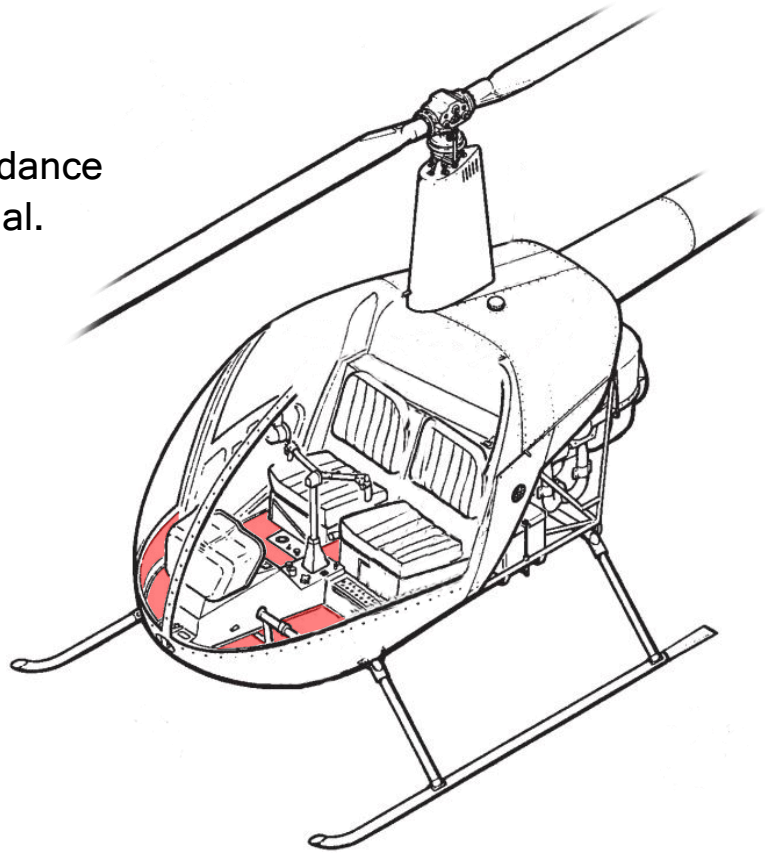
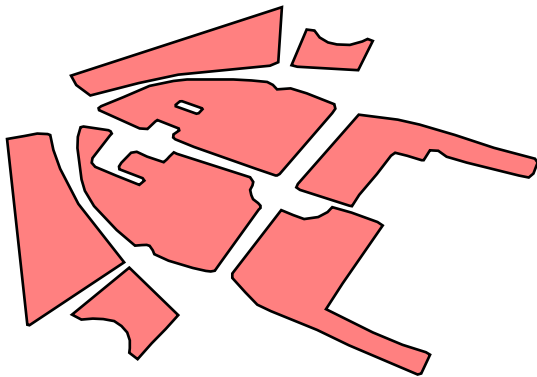

2. Take care to mask out any areas that may be affected by solvents and glues, such as Perspex windows and flight instruments.

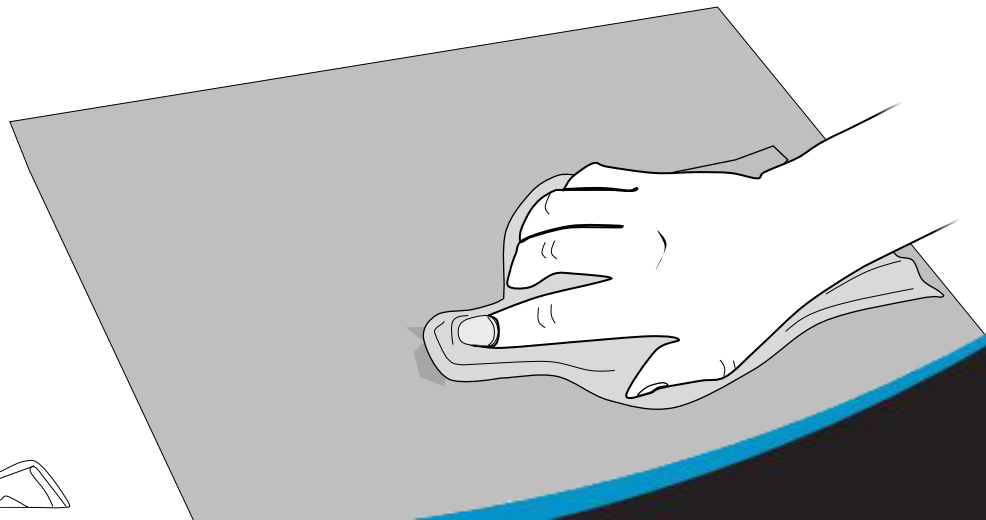

3. Verify proper fit of the new carpets and trim as required.

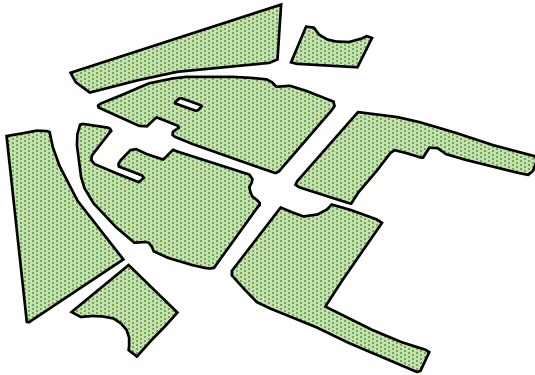

4. Apply glue the back of the carpets & to the prepared surfaces allowing it to tack off before applying the carpet. Press the carpet to the surface, smooth wrinkles & remove any excess prior to the adhesive curing

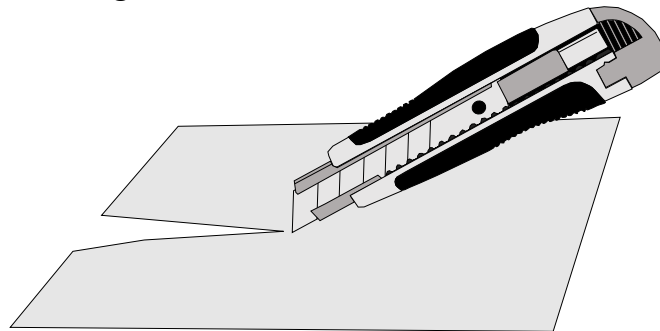

5. Install hardware securing scuff plates to cabin floor, if removed, in accordance with the R22 Maintenance Manual.



Cleaning Instructions:

Clean any excess glue away with a mild solvent taking care that the solvent does not damage any Perspex windows or Plastics, remove any masking that you may have used and vacuum clean the interior to remove any off-cuts of carpet or rubbish.

The carpet as standard has a synthetic back and will not break down immediately with water, however take care to avoid excess exposure to water and make all attempts to dry thoroughly and your carpets will last indefinitely.

Clean regularly with a vacuum cleaner and avoid build-ups of dirt, as this will destroy the pile quickly.

Recommended Products

- **Cleaning:** Dupont Prep-Sol. – Composites & metals  
Acetone – Composites & metals  
Water & mild soapy detergent – Fabric.
- **Glue:** Robinson B270-8  
Ados F2 (aerosol can)  
Ados F38  
Bostik Super-tac (aerosol can)  
Daley's A1000 (Australia)  
3M 1300

**Generation Global takes no responsibility for installation outside the instructions above and for use of solvents and chemicals used other than those recommended above, if in doubt refer to the Robinson Maintenance Manuals for the correct materials.**

# GENERATION

## GLOBAL

### Contact Information:

For further information please feel free to contact to our team with either of the below methods.

#### Email Contacts

[enquiry@generation-global.com](mailto:enquiry@generation-global.com)

#### Phone Contacts

USA: 714-485-2939

NZ: 0064 3 548 4225

AUS: 1800 104 973

32 Dakota Street  
Nelson 7010, New Zealand  
E: [enquiry@generation-global.com](mailto:enquiry@generation-global.com)  
Web: [www.shop.generation-global.com](http://www.shop.generation-global.com)